

VIRGO
CC60 / CC90

Right Angle Carton Closer Series

3S Packaging Technology, a spin-off from an English packaging machinery organisation, is looking back on more than 15 years of successful handling and integration of complete line solutions. From our manufacturing base right at the bottom of the Allgaeu Alps we supply the world market of food, chocolate, confectionery and consumer goods with "Made in Germany" designed, engineered and manufactured packaging machinery.

Reference projects can be found among frozen fish, hamburger and pizza, bars, biscuits, chewing gum, tea and baby food manufacturers as well as with providers of dish washer tablets, razor blades or fem-care products.

Our customers rely on our service and outstanding experience as Single Source Solutions provider - simply 3S.

The **Virgo** Series offers a large size range with rapid size change over and simply designed but robust construction. Designed for customers who require a fully automatic top load carton closer for speeds of up to 90cpm. The **Virgo** Series accepts random cartons with filled product and through carton control and a right angle indexing section delivers a square unmarked carton due to lug-less flights. The **Virgo** Series can handle every type of carton board and saves vast amounts of factory space through the right angled index.

The **Virgo** Machine is a member of the Top Load Closer family produced by 3S Packaging Technology. Other ranges of machinery include both carton lock and glue erectors, end loaders, robotic loaders and all types of product specific infeed systems.

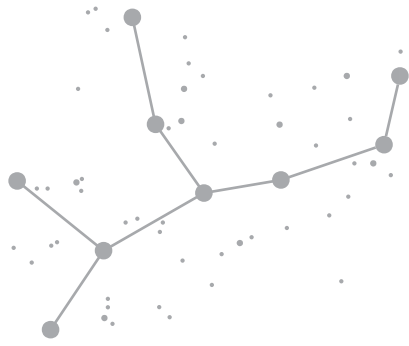
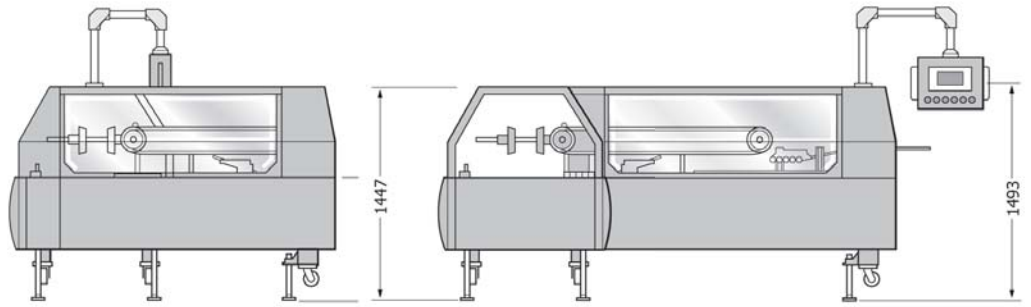

VIRGO CC60 / CC90

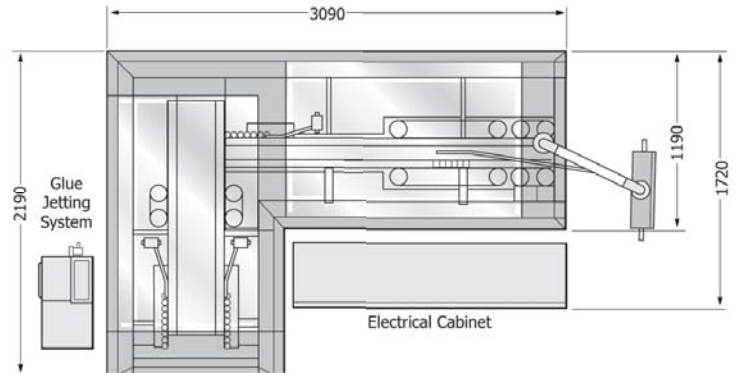

Standard Features

- Typical carton speeds, CC60 up to 60 cpm, CC90 up to 90 cpm
- Full visibility and access into the machine
- Completely random infeed
- Size change available in 10 minutes
- The PLC touch-screen allows all machine functions, including hot melt pattern to be adjusted
- Servo driven 90° indexing station ensures square entry into closing section
- Overhead running fingers assist with carton squareness and oversize product
- Simply designed but robust stainless steel construction
- Compact, space saving design

Optional Extras

- Hot air sealing
- Complete 'wash down' specification

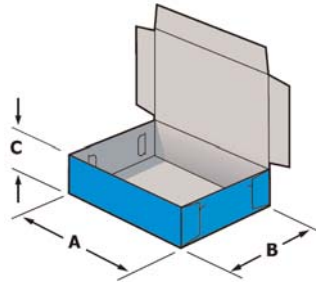

VIRGO

Machine model	Type	Speed cartons/min	Carton size			
			min	max		
CC60	90° Single Servo Transfer	60	A	100mm	A	325mm
			B	90mm	B	300mm
			C	19mm	C	120mm
CC90	90° Double Servo Transfer	90	A	100mm	A	325mm
			B	90mm	B	300mm
			C	19mm	C	120mm

NOTE: All maximums may not apply on the same carton. Maximum and Minimum sizes shown should be used as guide only and must be Confirmed by 3S Packaging Technology technical department.

ELECTRICAL SPECIFICATION

	Europe	USA
Mains supply	380/400V, 3 phase, 50Hz	240/480V, 3 phase, 60Hz
Control supply	24V DC	24V DC
Total electrical loading	5kW	5kW

Due to technical progress we reserve the right to make modifications without prior notice.