



## SCORPIUS ES200 / ES250

### End Load Cartoner Series

**3S PacTec** is looking back on 15 years of successful handling and integration of complete line solutions. From our manufacturing base right at the bottom of the Allgaeu Alps we supply the world market of food, chocolate, confectionery and consumer goods with „Made in Germany“ designed, engineered and manufactured packaging machinery.

Reference projects can be found among frozen fish, hamburger and pizza, bars, biscuits, chewing gum, tea and baby food manufacturers as well as with providers of dish washer tablets, razor blades or fem-care products.

Our customers rely on our service and outstanding experience as Single Source Solutions provider - simply 3S.

Designed to meet the highest customer demands. The fully automatic servo driven **Scorpius** End Load Cartoner Series provides the FMCG industries with very flexible cartoning operations at speeds up to 300 cpm. Linked to product specific loading systems the **Scorpius** cartoners with their infinitely variable drive concept and flexible size changing achieve integrated packaging solutions for most of the products from the food and non-food industry.

The **Scorpius** Machine is a member of the End Load Cartoning family produced by 3S PacTec. Other ranges of machinery include both carton lock and glue erectors, robotic loaders, a full range of carton closers and all types of product specific infeed systems.



# SCORPIUS

## ES200 / ES250

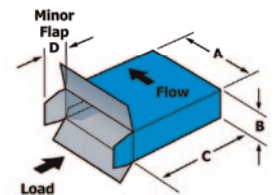
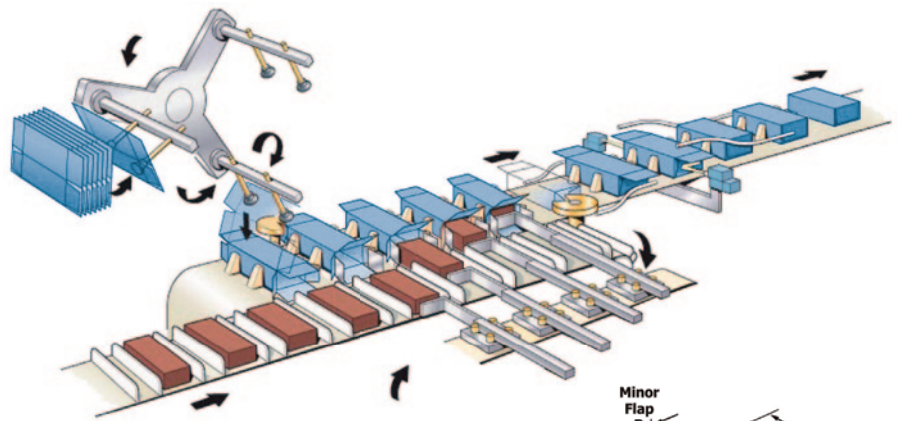
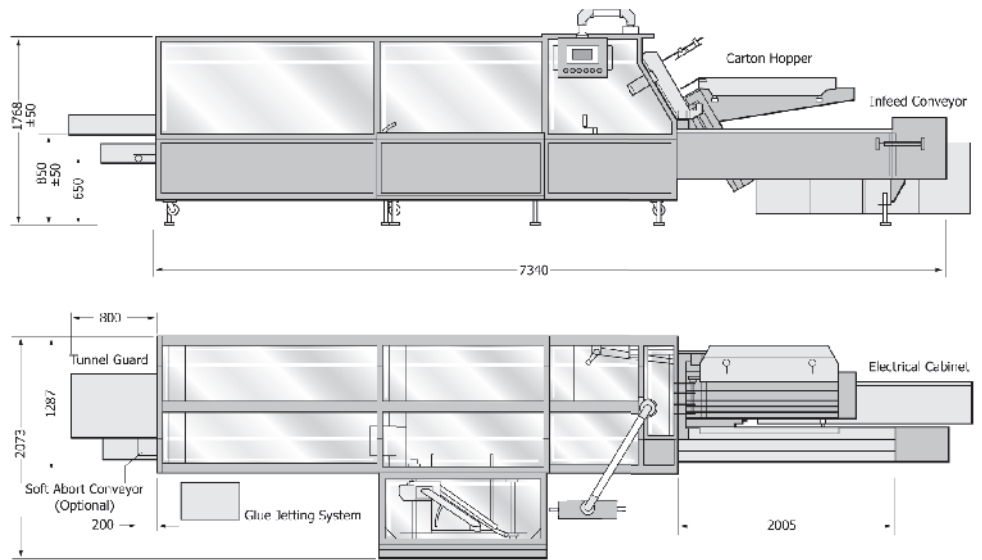

### Standard Features

- Size change available within 15 minutes
- Hot glue jetting system
- Rotary feeder available in 3 or 4 head versions
- Carton speeds up to 300 cpm - subject to carton size
- Servo motors drive flap tuckers, flight chains, product infeed, loader, transfer conveyors and rotary carton feeder independently
- Slide in and out gates accommodate the extended motorised carton magazine
- The PLC touch-screen allows all machine functions, including hot melt pattern to be adjusted
- Automatic adjustment of flight chains and product conveyor is achieved through the independent servo drives
- Powered outfeed belts
- Motorised carton magazine
- Product abort system

### Optional Extras

- A variety of different feed and loading options
- Additional fixed magazines for each carton size or adjustable magazine available
- One shot lubrication system
- Tuck-in closure

### SCORPIUS

Machine model	Type	Speed carton max per min	Carton size				Feed system
			min		max		
ES 200 12" Pitch	Automatic 3 head rotary	150	A 50 mm B 19 mm C 115 mm D 19 mm	A 254 mm B 100 mm C 305 mm D 40 mm	Manual or auto		
ES 200 9" Pitch	Automatic 3 head rotary	200	A 50 mm B 19 mm C 115 mm D 19 mm	A 178 mm B 100 mm C 305 mm D 40 mm	Manual or auto		
ES 250 6" Pitch	Automatic 4 head rotary	300	A 50 mm B 19 mm C 115 mm D 19 mm	A 102 mm B 100 mm C 305 mm D 40 mm	Manual or auto		

NOTE: All maximums may not apply on the same carton. Maximum and Minimum sizes shown should be used as guide only and must be confirmed by 3S PacTec technical department. Maximum speeds may vary subject to the carton size and the infeed pitch.

### ELECTRICAL SPECIFICATIONS

	Europe	USA
Mains supply	380/400V, 3 phase, 50Hz	240/480V, 3 phase, 60Hz
Control supply	24V DC	24V DC
Total electrical loading	4,5kW	4,5kW

Due to technical progress we reserve the right to make modifications without prior notice.