



CENTAURUS ES80



3S Packaging Technology, a spin-off from an English packaging machinery organisation, is looking back on more than 15 years of successful handling and integration of complete line solutions. From our manufacturing base right at the bottom of the Allgaeu Alps we supply the world market of food, chocolate, confectionery and consumer goods with "Made in Germany" designed, engineered and manufactured packaging machinery.

Reference projects can be found among frozen fish, hamburger and pizza, bars, biscuits, chewing gum, tea and baby food manufacturers as well as with providers of dish washer tablets, razor blades or fem-care products.

Our customers rely on our service and outstanding experience as Single Source Solutions provider - simply 3S.

Semi-Automatic End Load Cartoner

For customers who require a semi automatic machine with speeds of up to 80cpm. The **Centaurus** evolves from the Pegasus End Sealer Series, thus offering a large machine size range, can adopt lower grade carton materials, a rapid size change over and simply designed but robust construction. The hand load area is designed for 2 operators with a safety flap switch and an optional foot switch for optimal safety.

The **Centaurus** Machine is a member of the End Load Cartoning family produced by 3S Packaging Technology. Other ranges of machinery include both carton lock and glue erectors, robotic loaders, a full range of carton closers and all types of product specific infeed systems.

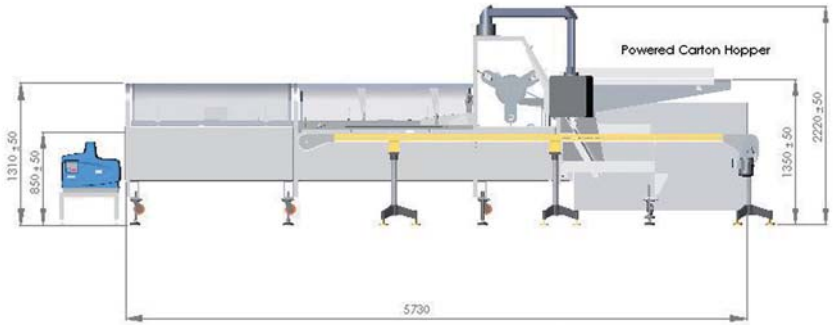

CENTAURUS ES80

Standard Features

- 2 head rotary carton feeder
- 1.6 m loading space for 2 operators
- Carton speeds up to 80 cpm - subject to carton size
- Fixed gates suited for each carton size
- Hot glue jetting system
- 'Feed on demand' switch for the operator
- Size change available within 10 minutes

Optional Extras

- Additional fixed magazines for each carton size or adjustable magazine available
- One shot lubrication system
- Infeed product transfer conveyor
- Powered outfeed belts
- Motorised carton magazine

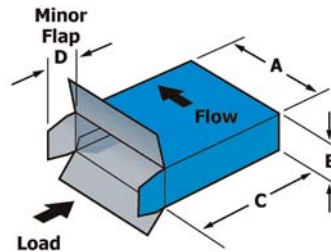
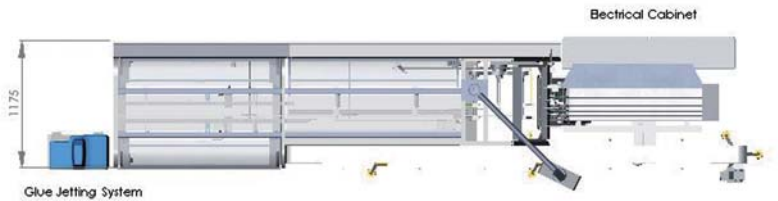

CENTAURUS

Machine model	Type	Speed carton max per min	Carton size		Feed system		
			min	max			
ES80	Automatic 2 head rotary	80	A	50mm	A	254mm	Manual product loading
			B	19mm	B	100mm	
			C	120mm	C	304mm	
			D	19mm	D	40mm	

NOTE: All maximums may not apply on the same carton. Maximum and Minimum sizes shown should be used as guide only and must be Confirmed by 3S Packaging Technology technical department. Maximum speeds may vary subject to the carton size and the infeed pitch.

ELECTRICAL SPECIFICATION

	Europe	USA
Mains supply	380/400V, 3 phase, 50Hz	240/480V, 3 phase, 60Hz
Control supply	24V DC	24V DC
Total electrical loading	4.5kW	4.5kW

Due to technical progress we reserve the right to make modifications without prior notice.