



**CASSIOPEIA**  
IS300 / IS700

## Integrated Robotic Top Load Cartoning System

**3S Packaging Technology**, a spin-off from an English packaging machinery organisation, is looking back on more than 15 years of successful handling and integration of complete line solutions. From our manufacturing base right at the bottom of the Allgaeu Alps we supply the world market of food, chocolate, confectionery and consumer goods with "Made in Germany" designed, engineered and manufactured packaging machinery.

Reference projects can be found among frozen fish, hamburger and pizza, bars, biscuits, chewing gum, tea and baby food manufacturers as well as with providers of dish washer tablets, razor blades or fem-care products.

Our customers rely on our service and outstanding experience as Single Source Solutions provider - simply 3S.

A single unit consisting of three modules, the **Cassiopeia** Series is designed to form, fill and close trays and cartons and eliminates the requirement for three separate machines and their associated space requirements.

Capable of forming cartons from flat blanks the **Cassiopeia** offers all the features of the 3S 'Gemini and Auriga Carton Formers'. These include lightweight carbon fibre lock tools, adjustable glue tools, powered hopper and quick size change functionality.

The **Cassiopeia** loading module incorporates the agility of the Aquila series and is available in single and triple race track formats. Capabilities range up to 700ppm on a triple racetrack format.

The closing module, the third function of the **Cassiopeia**, features technology developed for the 'Virgo' such as rubber fingers for carton control and quick size change performance.

Closing options include the closing of cartons with a hinged lid, front flap glue, separate lid closure and the folding or gluing of 4 upper flaps.

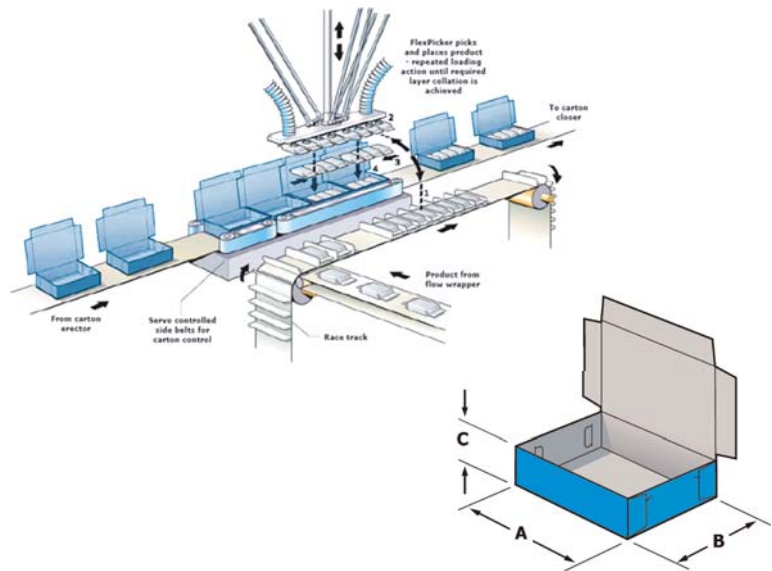
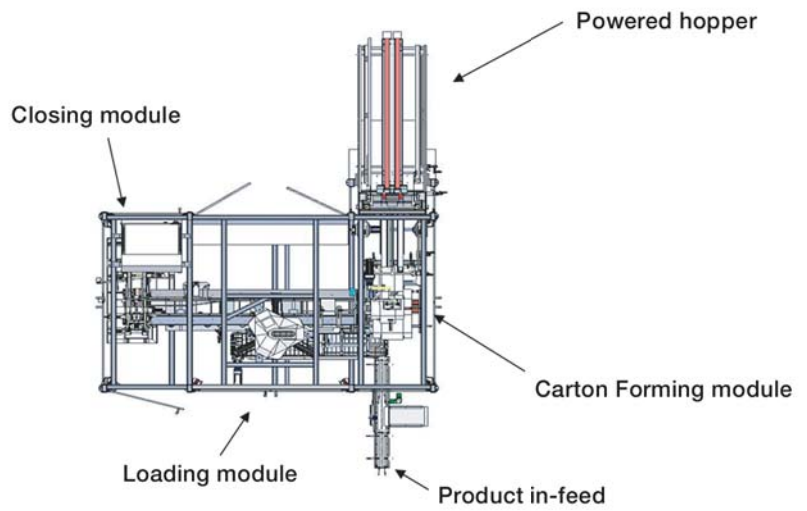

#### CASSIOPEIA

Machine model	Products/min	Carton size	
		min	max
IS300	300	A 100mm B 80mm C 20mm	A 300mm B 300mm C 150mm
IS700	700	A 100mm B 80mm C 20mm	A 300mm B 300mm C 150mm

NOTE: All maximums may not apply on the same carton. Maximum and Minimum sizes shown should be used as guide only and must be Confirmed by 3S Packaging Technology technical department.

#### ELECTRICAL SPECIFICATION

	Europe	USA
Mains supply	380/420V, 3 phase ~ N+PE, 50Hz	240/480V, 3 phase ~ N+PE 60Hz
Control supply	24V DC	24V DC
Total electrical loading IS300	12.5kW	14.5kW
Total electrical loading IS700	16kW	18.5kW

Due to technical progress we reserve the right to make modifications without prior notice.



#### Standard Features

- Typical product speeds, IS300 up to 300 ppm, IS700 up to 700 ppm
- Full visibility and access into the machine
- Random product infeed
- Size change available in 30 minutes (all 3 machine modules)
- The PLC touch-screen allows all machine functions, including hot melt pattern to be adjusted
- Servo driven 90° indexing station ensures square entry into closing section
- Overhead running fingers assist with carton squareness and oversize product
- Simply designed but robust stainless steel construction
- Compact, space saving design
- Cassiopeia loads multiple cartons / trays simultaneously
- Incorporates a robot with full access to technical back up and software / hardware upgrades
- Servo controlled belts transfer and space cartons / trays to exact positions for product loading
- Modular design allows flexibility between different carton configurations

#### Optional Extras

- Motorised carton magazine
- Extended carton magazine
- Vacuum take-away conveyor
- Complete 'wash down' specification
- Fixed size forming head and plunger per carton size, per lane (lock carton)
- Fully adjustable forming head to run all sizes of carton within machine range (glue carton)
- Double glue guns / nozzles for deep cartons (glue carton)
- Product pockets for different sizes
- Upgrade to 5 kg payload