



AURIGA CF70 / CF120 / CF180

Fully Servo Driven Glue Former Series

3S PacTec is looking back on 15 years of successful handling and integration of complete line solutions. From our manufacturing base right at the bottom of the Allgaeu Alps we supply the world market of food, chocolate, confectionery and consumer goods with „Made in Germany“ designed, engineered and manufactured packaging machinery.

Reference projects can be found among frozen fish, hamburger and pizza, bars, biscuits, chewing gum, tea and baby food manufacturers as well as with providers of dish washer tablets, razor blades or fem-care products.

Our customers rely on our service and outstanding experience as Single Source Solutions provider - simply 3S.

The **Auriga** Series is designed for customers who require glued cartons ready for automatic or manual loading at speeds of up to 180 cpm. The full servo **Auriga** Carton Former has independent axis driving each station for complete flexibility between carton sizes. A low level carton magazine makes life easy for the operator, along with quick size changing through the adjustable magazine and quick release plungers and lightweight carbon fibre forming heads. The **Auriga** Series is available in single, double or triple heads giving respective speeds of 70 cpm, 120 cpm and 180 cpm.

The **Auriga** Machine is a member of the Top Load Carton Erector family produced by 3S PacTec. Other ranges of machinery include end loaders, robotic loaders, a full range of carton closers and all types of product specific infeed systems.

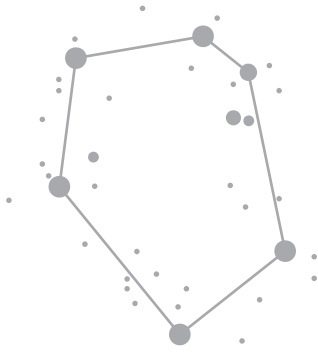
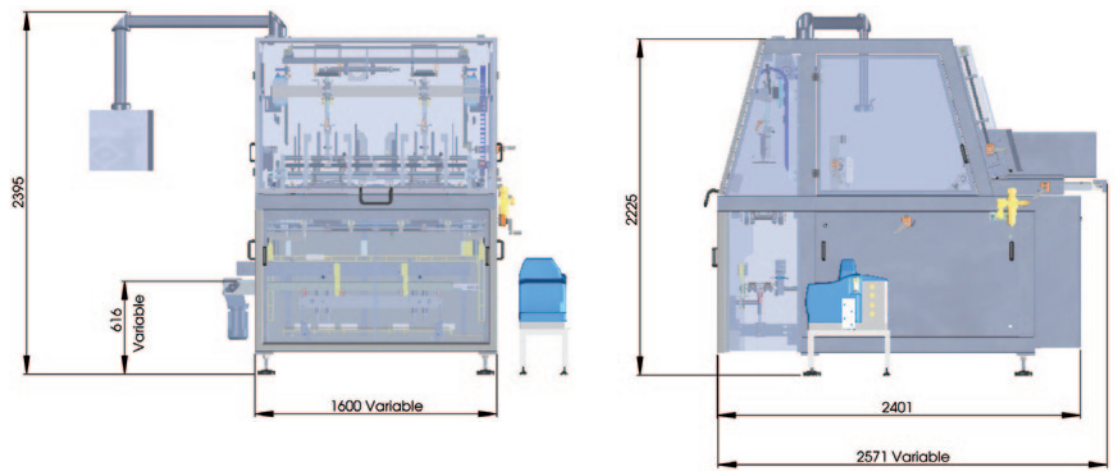

AURIGA

CF70 / CF120 / CF180

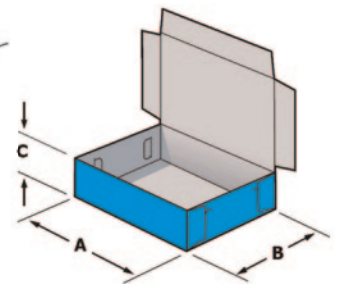
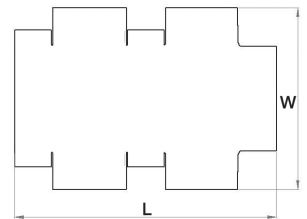
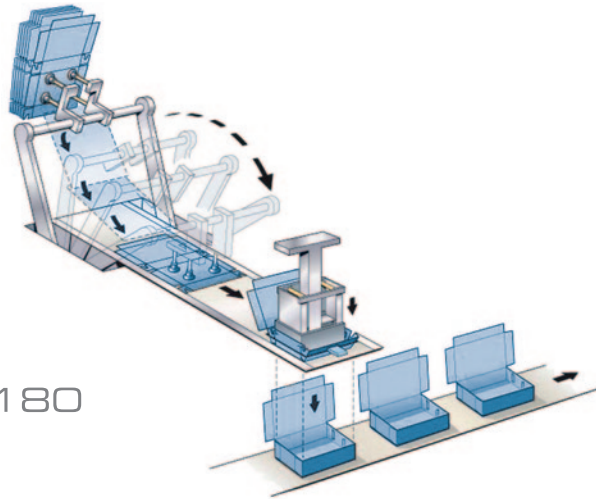

Standard Features

- Typical carton speeds, CF70 up to 70 cpm, CF120 up to 120 cpm, CF180 up to 180 cpm
- Maintenance free
- Simply designed but robust stainless steel construction
- Full visibility and access into the machine
- Servo Motors drive all axis independently
- The PLC touch-screen allows all machine functions to be adjusted
- Magazine level control
- Low carton magazine for easy filling
- Size change available within 10 minutes
- Indirect blank feeding
- Carton erect control under tooling

Optional Extras

- Motorised carton magazine
- Extended carton magazine
- Vacuum take-away conveyor
- Double glue guns / nozzles for deep cartons
- Fully adjustable forming head to run all sizes of carton within machine range
- Different sizes can be formed simultaneously in different lanes (e.g. base and lid)
- Other means of forming (e.g. turn-over-end) are available on request

AURIGA

Former width model	Carton type	Forming Head Carton Blank Size LxW			Output cartons/min		
		Triple CF 180	Double CF 120	Single CF 70	Triple CF 180	Double CF 120	Single CF 70
1.200	Gluing	n. a.	760 mm x 260 mm	760 mm x 600 mm	n. a.	n. a.	70
1.600	Gluing	n. a.	760 mm x 360 mm	760 mm x 720 mm	n. a.	120	70
2.000	Gluing	760 mm x 240 mm	760 mm x 460 mm	760 mm x 920 mm	180	120	70

NOTE: Maximum and Minimum sizes shown should be used as guide only and must be confirmed by 3S PacTec technical department.

ELECTRICAL SPECIFICATIONS

	Europe	USA
Mains supply	380/400V, 3 phase, 50Hz	240/480V, 3 phase, 60Hz
Control supply	24V DC	24V DC
Total electrical loading	9,3kW	9,3kW

Due to technical progress we reserve the right to make modifications without prior notice.