



AQUILA
TL300 / TL700

Robotic Top Loader Serie

3S PacTec is looking back on 15 years of successful handling and integration of complete line solutions. From our manufacturing base right at the bottom of the Allgaeu Alps we supply the world market of food, chocolate, confectionery and consumer goods with „Made in Germany“ designed, engineered and manufactured packaging machinery.

Reference projects can be found among frozen fish, hamburger and pizza, bars, biscuits, chewing gum, tea and baby food manufacturers as well as with providers of dish washer tablets, razor blades or fem-care products.

Our customers rely on our service and outstanding experience as Single Source Solutions provider - simply 3S.

Designed for the optimum flexibility in robotic product top loading, the **Aquila** Series offers product speeds of up to 700ppm with a triple race track and product speeds of up to 300ppm with a single race track.

This full servo system accepts fully random product and collates into the required row and layer number through the racetrack and robot, replacing the need of many hand loading operators and labour.

The **Aquila** Machine is a member of the Top Load Robotic Loader family produced by 3S PacTec. Other ranges of machinery include both carton lock and glue erectors, end loaders, a full range of carton closers and all types of product specific infeed systems.

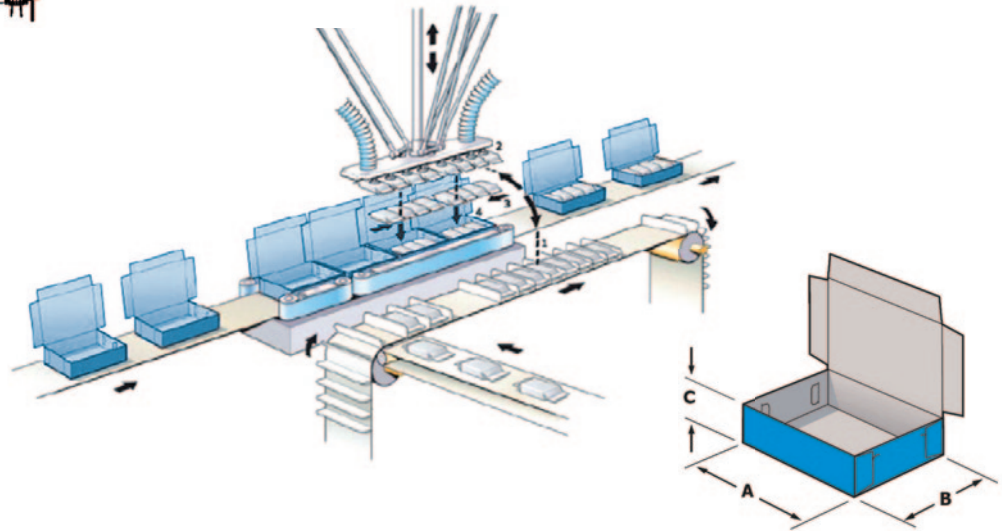
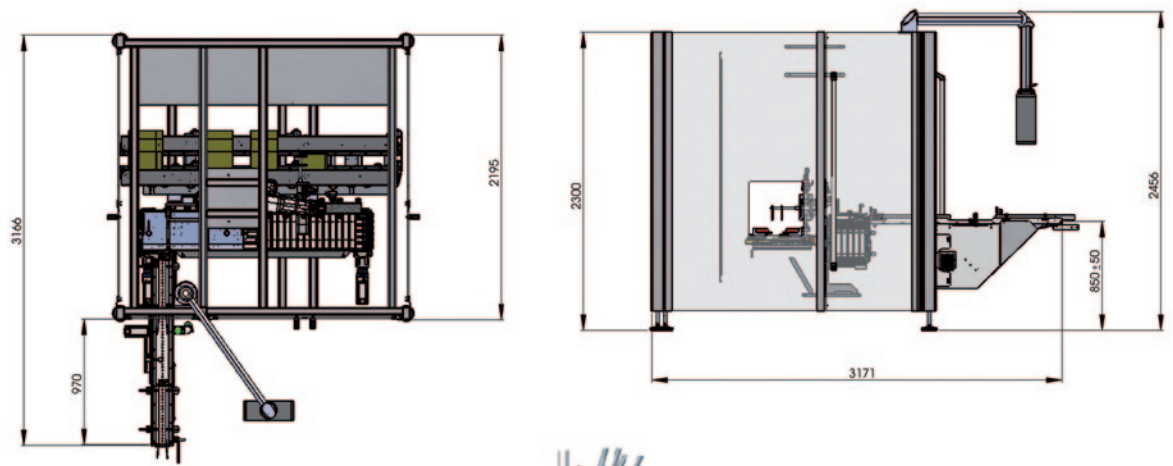

Standard Features

- Random product infeed
- Aquila loads multiple cartons / trays simultaneously
- Typical product speeds, TL300 up to 300 ppm, TL700 up to 700 ppm
- The PLC touch-screen allows all machine functions to be adjusted
- Incorporates a robot with full access to technical back up and software / hardware upgrades
- Size change available in 15 minutes
- Servo controlled belts transfer and space cartons / trays to exact positions for product loading
- Modular design allows flexibility between different carton configurations
- Full visibility and access into the machine
- Simply designed but robust stainless steel construction

Optional Extras

- Electronic interface with upstream / downstream packaging machines
- Upgrade to 5 kg payload

AQUILA

Machine model	Products/min	Carton size			
		min		max	
TL 300	300	A	100 mm	A	405 mm
		B	80 mm	B	300 mm
		C	20 mm	C	150 mm
TL 700	700	A	100 mm	A	405 mm
		B	80 mm	B	300 mm
		C	20 mm	C	150 mm

NOTE: All maximums may not apply on the same carton. Maximum and Minimum sizes shown should be used as guide only and must be confirmed by 3S PacTec technical department.

ELECTRICAL SPECIFICATION

	Europe	USA
Mains supply	380/400V, 3 phase, 50Hz	480V, 3 phase, 60Hz

Due to technical progress we reserve the right to make modifications without prior notice.